

Feed Bagging Machine With Single Weigh Hopper and Single Station 25-50 Kg.

Genç Değirmen
MILLING MACHINERY

Excellent Milling Properties...

CAPACITY INFORMATION:

While it varies according to the product to be bagged and the tolerance required, the values relating to the packaging speed below shall provide some information about the capacity of the system.

- 8,5 ton/hour in 25 kg bagging
- 15 ton/hour in 50 kg bagging

The tolerance per package varies between ± 0.15 kg in the 50-kg packaging. In addition to this, it is undertaken to be operated with 15 ton/hour capacity in the products such as flour or in similar characteristics with the average error share per package.

PACKAGING SET VALUES

The package filling weights could be preferred between 25-50 kg by the operator.



Feed Bagging Machine With Single Weigh Hopper and Single Station 25-50 Kg.

Product Data Sheet



Feed Bagging Machine With Single Weigh Hopper and Single Station 25-50 Kg.

Product Data Sheet

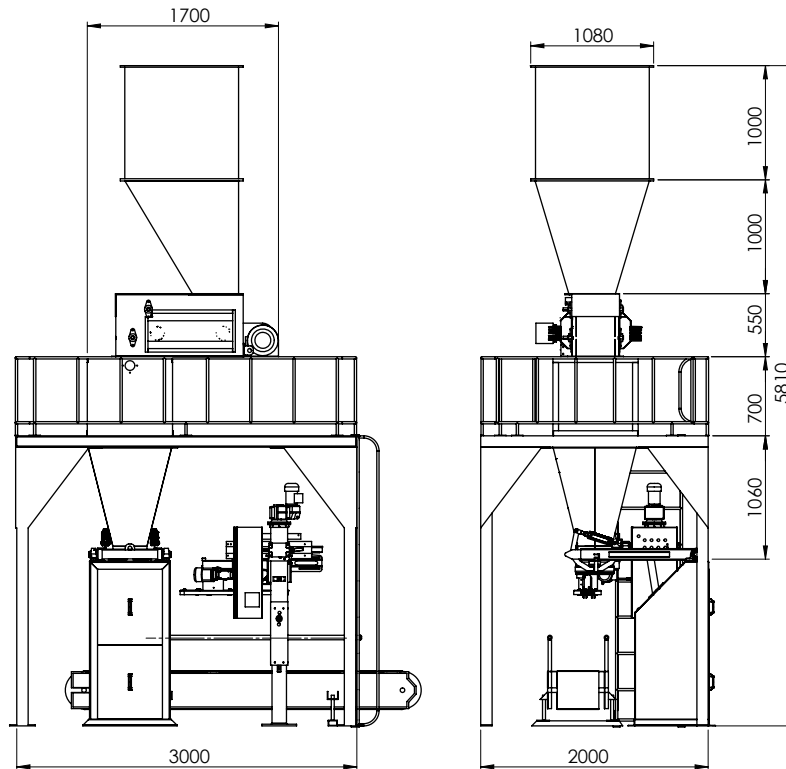

TECHNICAL FEATURES	
Type of Product to Be Packed	Feed
Density (Flour)	0,60 kg/m ³
Maximum Weighing Weight	60 Kg
Weighing Range -Options	25 - 50 Kg
Weighing Accuracy	±% 0,3
Top Bunker Capacity	1502 Liter
Platter Capacity	110 Liter
Output Capacity 15 Kg	8,75 Ton/Hour
Output Capacity 50 Kg	15,00 Ton/Hour
Weighing Units 15 Kg	350 Pack./Hour
Weighing Units 50 Kg	300 Pack./Hour
System Pressure	6 - 8 Bar
Air Supply (m ³ /Min)	10 m ³ /Min
Power Supply (VAC) (+5% - 10%)	400 VAC / 50-60 Hz.
Electricity consumption	3,55 kW/Hour
Weight	1680 Kg