

Bucket Elevator

GEV

Genç Değirmen
MILLING MACHINERY

Excellent Milling Properties...

WORKING PRINCIPLES

Bucket Elevator is used to vertical transporting without damage. Transporting operation has be done by plastic or metal buckets which integrated on purposeful rubber band.



Product Data Sheet

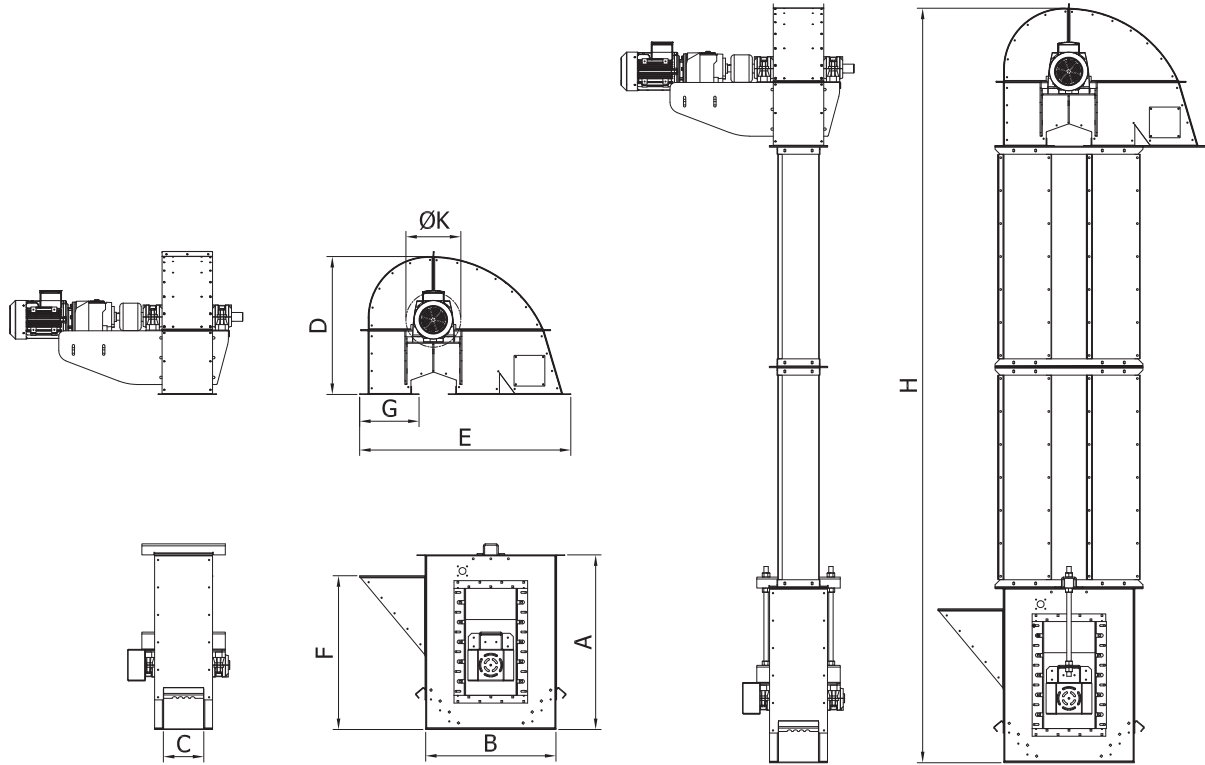

Type	Technical Features							Dimensions (mm)							
	Max Length (m)	Bucket	Belt (mm)	Power (kW)	Capacity (t/h)			A	B	C	D	E	F	G	ØK
					Wheat	Flour	Bran								
GEV 250/150	30	100-120	140	0.75-3	7.5	5.5	3	756	700	178	657	963	653	2115	250
GEV 320/190	30	140-160	180	1.5-5	20	16	8	816	700	223	780	1137	713	268	320
GEV 400/240	30	180-200	220	1.5-7.5	32	27	14	1007	805	275	968	1358	903	3025	400
GEV 500/360	30	280-300	320	7.5-15	80	65	34	1238	1049	424	1343	1728	1135	3815	500