

Hammer Mill

GDC

Genç Değirmen
MILLING MACHINERY

Excellent Milling Properties...

WORKING PRINCIPLES

Hammer mill is designed to meet almost any particle size reduction need and are capable of fine - grinding either friable or fibrous materials.

FEATURES

- Fast - Easy Screen And Hammer Change
- Easy Access To The Screens
- Less Power Consumption
- Wide Range Of Particle Size Production



Product Data Sheet

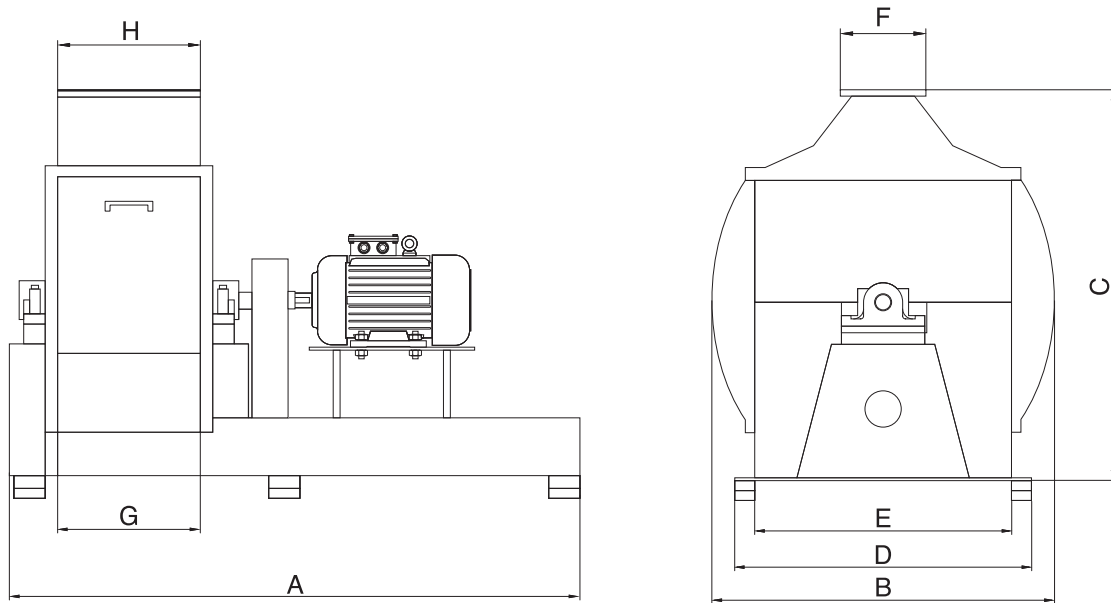

Type	Technical Features		Dimensions(mm)								Weight (kg)
	Capacity (t/h)	Power (kW)	A	B	C	D	E	F	G	H	
GDC 50/300	0.5-0.7	11-15	1350	780	830	600	500	250	300	380	400-500
GDC 50/400	1-1.2	11-18.5	1450	780	830	600	500	250	400	480	560
GDC 65/400	1.5-1.7	18.5-22	1500	940	1020	750	650	280	400	480	650-800
GDC 65/500	2	22-30	1600	940	1020	750	650	280	500	580	975