

Separator With Eccentric Pulley

GES

Genç Degirmen
MILLING MACHINERY

Excellent Milling Properties...

WORKING PRINCIPLES

It is used to separate unwanted things in the grain with their size by circular oscillatory motion. Product becomes clean by centrifugal force which occurs thanks to circular oscillation. Sifter sheets size and types are changeable according to product type.



Product Data Sheet

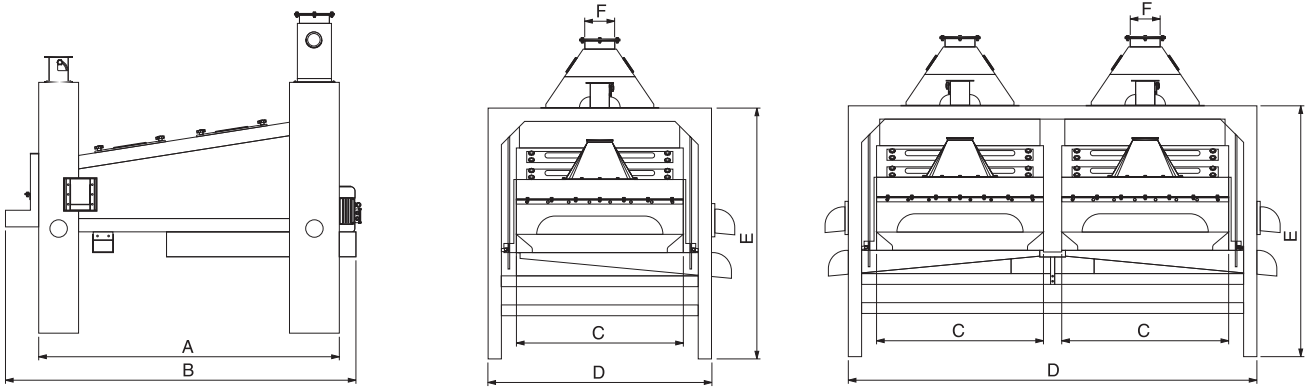

Type	Technical Features			Sieve Dimensions (mm)	Dimensions (mm)						Weight (kg)
	Capacity (t/h)		Power (kw)	Width x Length	A	B	C	D	E	ØF	
	*Pre-Cleaning	*Cleaning									
GES 100/180	30-35	12-14	1.1	2x990x1790	1300	1420	1000	1300	1255	180	455
GES 140/180	35-40	14-16	1.5	2x1390x1790	1800	2000	1400	1700	1255	180	550
GES 270/180	50-60	20-24	2.2	2x990x1790	1300	1420	1000	2400	1255	180	960

* Capacity has given as per 2 to 3 % impurity and maximum %13 humidity.

* Capacity for corn (maize) 90%

* Capacity for barley 80%