

Selector

GSS

Genç Degirmen

MILLING MACHINERY

Excellent Milling Properties...

WORKING PRINCIPLES

It used for separate coarse, thin and light materials from grain, it does that operation by sifting and air aspiration by air occurred machine itself.

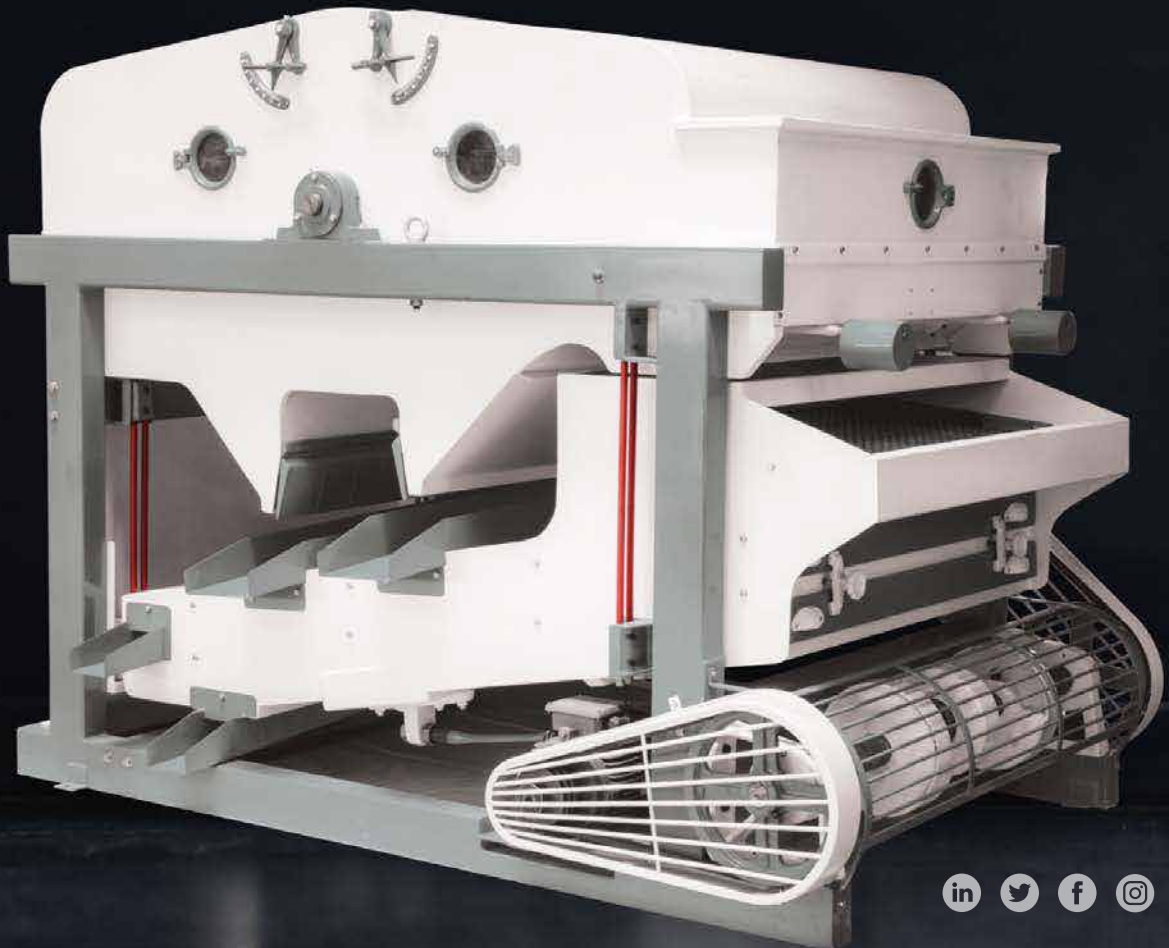

Product Data Sheet

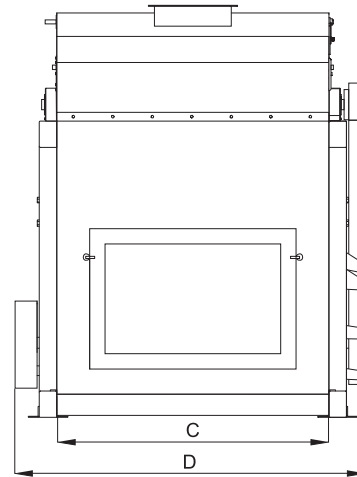
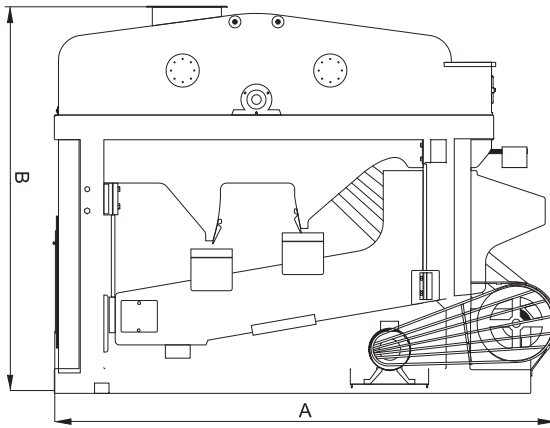

Type	Technical Features			Dimensions(mm)				Weight (kg)
	Capacity(t/h)	Volume(m ³)	Power(kw)	A	B	C	D	
GSS 100/180	6-10 8-14	3.3	3	2350	1850	1000	1400	960
			4					1000
			1.1					985
GSS 120/180	12-14 14-18	4.5	4	2840	2120	1200	1680	1305
			5.5					1350
			1.1					1335
GSS 160/180	18-22 25-30	6.5	4	2900	2250	1600	1950	1755
			5.5					1800
			1.5					1780
GSS 180/180	25-30 40-45	8.2	5.5	3260	2530	1800	2190	2025
			1.5					20000
GSS 180/200	30-35 45-50	10	7.5	3600	2810	1800	2430	2250
			1.5					2230